

POWERBOAT GUIDE

ENGINES AND ACCESSORIES



CONTENTS

Highlights

What's new for easier, even more enjoyable boating 4

Benefits of Volvo Penta power

Safer and greener boating from Volvo Penta 6

Aquamatic

The leading sterndrive system. Diesel and gasoline 10

Volvo Penta IPS

The forward-facing pod system that represents a new era
in inboard propulsion 18

Diesel inboard

Inboard shaft diesel technology all the way to 900 hp 28

Controls

A new generation of controls. More features for easy docking
and smooth cruising 30

Accessories

Customize your boating with instrumentation, software and accessories.
EVC accessory packages for easy installation 32

Specifications

All the data on one spreadsheet 38

Visit volvopenta.com for further information, films, product bulletins and more.

MAKING IT **EASY**





Volvo Penta continues to make your boating easy and intuitive. Because easy means safe and fun driving. The successful joystick is the most obvious example of this, making docking a sheer pleasure.

We are now introducing a new generation of controls with integrated functionality, new driving features and larger Volvo Penta IPS models. So take the helm and enjoy the moment!

The green commitment continues. This year with the introduction of Volvo Penta IPS1050 and IPS1200, making great exhaust emission reductions possible for yachts up to 100 feet.



BOATING **EVOLUTION**

The new driver interface makes your boating easier and more enjoyable. Now completed with new-generation controls that let you manage much more than shift and throttle!



VOLVO PENTA IPS FOR SEMI-PLANING BOATS

Enjoy the benefits of Volvo Penta IPS350 to IPS600 also for trawlers and other semi-planing boats. Better onboard comfort, joystick docking and – get this – no irritating diesel fumes on the aft deck.

A NEW ERA FOR YACHTS

The new IPS1050 and IPS1200 are the biggest yet, giving exceptional efficiency to boats up to 100 feet. Powered by the D13 marine diesel coupled to a new larger and perfectly matched pod.

Pages 18-27



The new D13-800.
Page 29.

NEW GENERATION AT THE HELM

With the new generation driver interface, form and function go hand in hand with fingertip command and all information available – tailored to your preferences.

Pages 30-34



DEVELOPED **FOR MARINE USE**

Built on more than 100 years of marine experience, Volvo Penta gives you a better boating experience thanks to safe and predictable handling, rapid acceleration, high onboard comfort and excellent reliability.



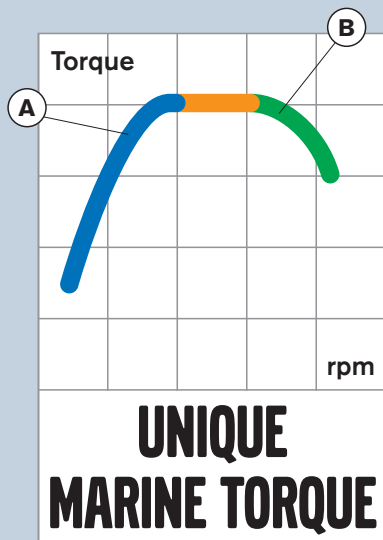

UNIQUE MARINE TORQUE

The key to maximum performance and easy maneuvering. A Volvo Penta hallmark.

A. High torque at low rpm gives you:

- Rapid acceleration to plane.
- Massive maneuvering power.

B. At high rpms, full-throttle torque increases if the engine loses rpm. You get:

- Efficient cruising speed even in rough seas or with a fully loaded boat.

EVC – ELECTRONIC VESSEL CONTROL

EVC is Volvo Penta’s common electronic platform with radically reduced wiring and heavy-duty marine connectors. EVC gives greatly improved reliability and new functionality:

- Continuous monitoring of engine and transmission.
- Safety functions protecting transmission and engine.
- Easy to add new functionality.

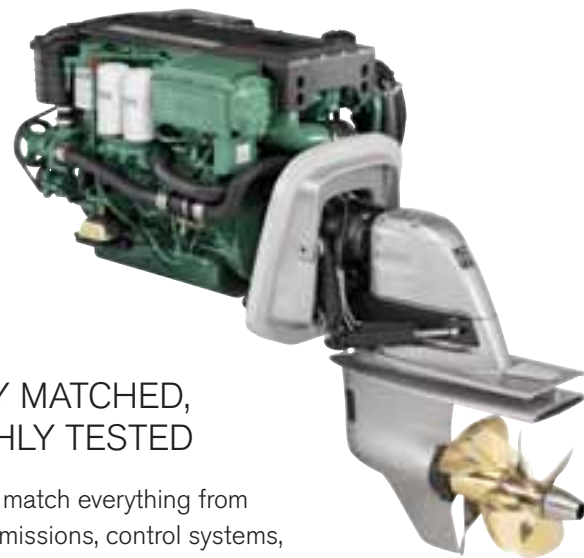

PERFECTLY MATCHED, THOROUGHLY TESTED

We develop and match everything from engines to transmissions, control systems, drives and propellers. For the boater, this results in higher reliability and better performance.



DEVELOPED, MANUFACTURED AND SERVICED BY ONE COMPANY

Volvo Penta gives you one single contact for the whole package.

MORE PERFORMANCE LESS CO₂

Reducing CO₂ emissions is a challenge Volvo Penta takes seriously and works with constantly. By combining clean engines with efficient drive systems and accessories that enable eco-driving, we are able to offer a seemingly impossible combination: more performance with less CO₂.

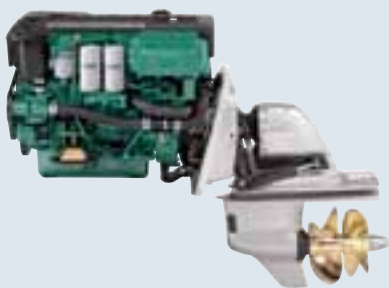

Performance with fuel efficiency

The Volvo Penta common rail diesel Aquamatic offers absolute top-class performance – with 30% less fuel consumption and CO₂ emissions compared with gasoline alternatives.

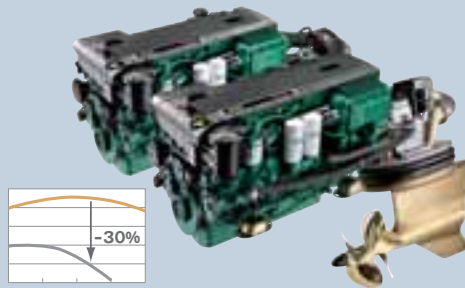

The Volvo Penta IPS revolution

In one stroke, the Volvo Penta IPS reduced fuel consumption and overall emissions for planing hulls by around 30% compared with inboard shafts. A gigantic improvement by any standard.



Exceeds stringent demands

The entire D-series diesel engine range complies with the most rigorous environmental demands: US EPA – a regulation significantly more stringent than the European RCD regulation.



Gasoline catalytic converter

Our 8-cylinder gasoline engines are available with catalytic converters that dramatically reduce emissions. They comply with US EPA and California's CARB 4 star, two of the world's most stringent marine engine emission standards.



ECO-DRIVING

Your driving style has a significant impact on fuel consumption and thereby CO₂ emissions. Volvo Penta offers a number of user-friendly accessories to minimize environmental impact.



The Trip Computer shows instant fuel consumption per nautical mile. An essential tool that makes it easy to adapt speed and trim for optimal efficiency.

Powertrim Assistant. Automatically gives you the best possible drive trim. The result is a perfect running attitude for optimum performance and low fuel consumption.



Auto Boat Trim system. Fast-acting interceptor trim system that automatically gets your boat to the correct trim angle for the lowest possible fuel consumption.

THE BENEFITS OF AQUAMATIC:

- Low fuel consumption
- Sporty performance
- Low CO₂ emissions
- Low noise and vibrations
- Excellent low-speed maneuverability
- Beach and shallow water tilt
- Joystick docking (optional)
- Powertrim Assistant (optional)



Diesel Aquamatic with Duoprop drive gives the same high efficiency as Volvo Penta IPS. Approximately 30% better than inboard shafts at cruising with planing hulls.

AQUAMATIC

THE PERFORMANCE PROVIDER

Volvo Penta Aquamatic sterndrive is a fully matched package where everything – helm station, engine, drive and propellers – is developed together and perfectly matched. This is why you can be sure to get high performance, sporty handling and great boating pleasure.

**Duoprop gives you:**

- Straight tracking – even in reverse
- Faster acceleration
- Low fuel consumption
- Quicker onto the plane
- Safe and predictable handling
- Lower vibration and noise



D4 AND D6 DIESEL ENGINES



DPH

Developed to handle the tremendous torque of the D4 and D6 diesel engines. External hydraulic steering cylinders, patented X-act steering and propellers give optimum driving safety and enjoyment.



DPR

High-speed version of the DPH drive for the D4 and D6, delivering perfect control for boats with top speeds above 45 knots.

D3 DIESEL AND GASOLINE ENGINES



SX

Perfect reliability and performance. Hydrodynamic design and low weight for better speed and performance. For D3 diesels and 4.3–5.7L gasoline engines.



DPS

For D3 diesels and 4.3–8.1L gasoline engines, providing amazing driving feel and safety. Hydrodynamic design and low weight for higher speed and better performance.

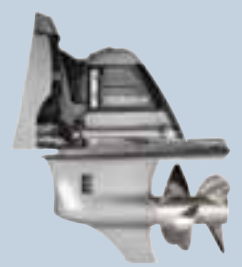

OceanX

For D3 diesels and 5.0–8.1L gasoline engines. Expressly developed titanium-ceramic coating and a drive monitoring sensor package (gasoline only) applied to our base DPS drive. Available only in selected markets.

STERNDRIVE JOYSTICK AND MORE

A new level of easy and intuitive boating is now available with Aquamatic. Dock with a joystick and drive intuitively with the new generation of controls – tailored to your own preferences.

Sterndrive joystick

Control your boat totally intuitively: move sideways, diagonally, forward, spin around or any combination. Docking and close-quarter maneuvering becomes easy and fun!

The joystick is available for twin installations – diesels and gasoline V8 engines with Duoprop drives.

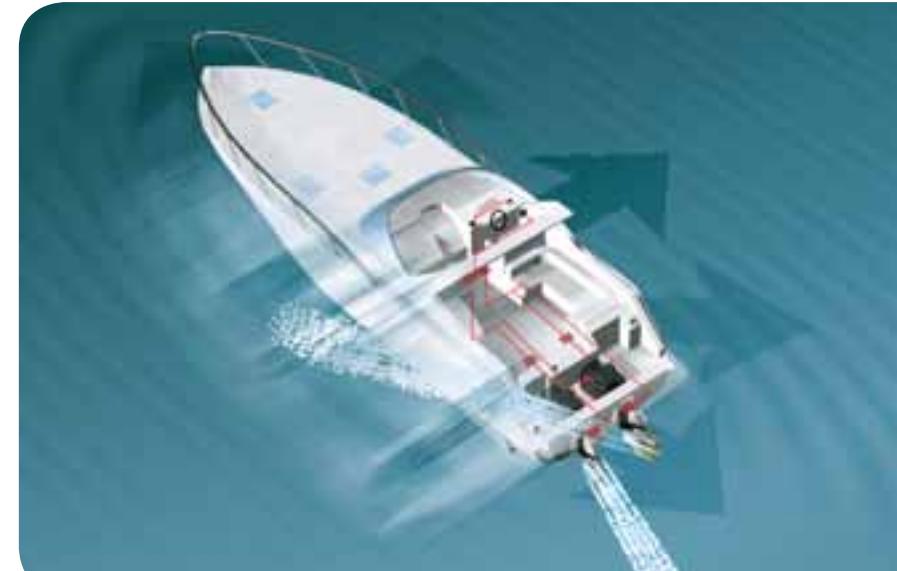

You can move your boat in any conceivable direction – with just the joystick. Special software transforms your joystick commands to boat movements by controlling engine rpm and gear shift plus the individually steerable Aquamatic drives. The joystick requires electronic steering.

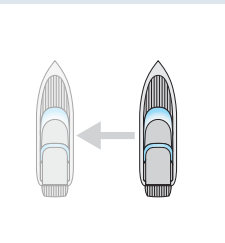

Push the joystick to port or starboard and your boat goes sideways. Even "impossible" berths are now accessible.

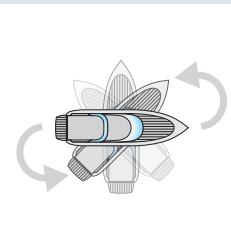

Twist the top to rotate. Combine it with any other move to compensate for wind or current.

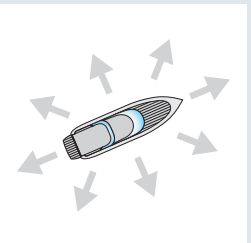

You can do all your slow-speed driving with the joystick. Much easier than the conventional way!



YOUR COMMAND CENTER FOR A PERFECT RIDE

The new generation of controls is your complete command center with all essential functions easy to reach.

Powertrim

Thumb control in the lever. In twin installations, both drives are trimmed in sync with this button. For individual drive trim, there are twin buttons on the front of the control.

Tailor your control!

You can get push-button control for many of your engine and drive features, e.g. single-lever mode, cruise control and Powertrim assistant.

All the details on page 31.



Top-mounted control for twin installation.



TOW-MODE FOR WATER SPORT

Now available for all single Aquamatic installations with the side-mounted control. When activated, the engine is limited to your preset maximum rpm, and maintains that speed, compensating for any changes in load. Easy to fine-tune with +/- buttons. This gives perfect speed all the time, every time, for maximum water sport fun.

Side-mounted control.



DIESEL AQUAMATIC RANGE

The diesel Aquamatic range is from 140 to 370 hp, giving sport performance to boats from around 17 to over 45 feet. Complete packages with common-rail diesels, matched drive and propellers, and electronic controls as standard on all models.



D3 Sport diesels

The lightweight champion with outstanding acceleration and sporty performance. Still with the low fuel consumption and reliability of a marine diesel.

D3 – IMPRESSIVE PERFORMANCE

Sporty performance from an in-line, 5-cylinder, common-rail diesel with up to 220 hp. Robust design and electronic controls as standard. Complies with the world's most stringent emission demands. Compact and light – only 363 kg/799 lbs complete with DPS drive.

Drives: SX or DPS.

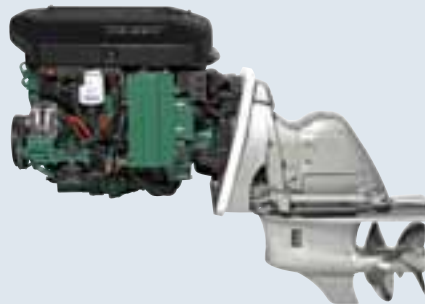

D4 – COMPACT AND POWERFUL

4-cylinder compressor (300 and 260) and turbo-charged, 3.7-liter, common-rail diesel with 260 or 300 hp. Comparable to V8 big-block gasolines in performance and size – at about half the fuel consumption. Enhanced onboard comfort thanks to integrated balance shafts and optimized engine mounts.

Drives: DPH or DPR.





Aquamatic gives an uncluttered transom for free access to the water.

EVC features

Electronic controls (shift & throttle)	●
Engine protection	●
Engine monitoring	●
Engine diagnostics	●
Engine synchronization	●
Up to 4 helm stations	●
Transmission protection	●
Engine alarms in text	●
Plug-in instrument installation	●
NMEA 2000 interface	○
Trip computer	○
Instrumentation dimmer	●
Depth, seawater temp and speed	○
▶ Tow-mode ⁴⁾	○
▶ Cruise control	○
▶ Single-lever mode ⁵⁾	○
Joystick ^{1,2)}	○
Docking station ^{1,2)}	○
Autopilot interface ^{1,2,3)}	○
Electronic steering ¹⁾	○
Powertrim sync ⁵⁾	●
Powertrim Assistant	○
Adjustable trim limits	●

● Standard ○ Optional ▶ New

¹⁾ Twin installation Duoprop drives. ²⁾ Requires electronic steering. ³⁾ Volvo Penta certifies marine autopilot manufacturers for compatibility with Volvo Penta Aquamatic. ⁴⁾ Single installation. ⁵⁾ Twin installation.

What is standard or optional varies by market.



Accessory packages
Read more on page 37.

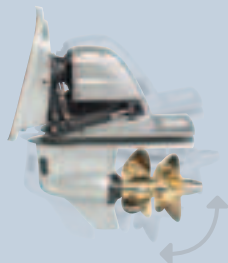

Powertrim Assistant

Automatically gives you the best possible drive trim. The result is a perfect running attitude for optimum performance and low fuel consumption. Page 31.



Cruise control

The driver can fine tune speed with the easy-to-reach button on the control. Page 31.

D6 – THE WORLD’S MOST POWERFUL DIESEL STERNDRIVE

The D6 with its 330 or 370 hp has opened up Duoprop benefits for boats up to +45 feet. Common rail, 6 cylinders, in-line, 5.5 liter displacement, mechanical compressor on the 370 version.

Drives: DPH or DPR.



Single-lever mode

Operate twin engines with one lever. Easy and precise even in rough seas.



Power range 140–370 hp

	Power (hp)			
D3	140	170	200	220
D4	225	260	300	
D6	330	370		

Complete technical data on page 39.

GASOLINE AQUAMATIC RANGE

Sporty boating with V6 and V8 packages delivering gasoline performance. The V8 models are available with catalytic converters that dramatically reduce emissions to a level that complies with California's CARB 4 Star and the US EPA emission requirements.



Catalytic converter

Our V8 gasoline engines are available with catalytic converters that dramatically reduce emissions to a level that complies with California's CARB 4 Star Super Ultra Low emission requirements and meets the US EPA emission requirements.

4.3 – SMOOTH-RUNNING V6

Virtually vibration-free running thanks to a centrally mounted balance shaft. Available with carburetor at 190 hp and MPI at 225 hp.

Drives: SX or DPS



5.0/5.7 – SMALL-BLOCK V8

The small-block V8s come with 5.0 and 5.7 liter displacement and MPI. Three power options at 270, 300 and 320 hp.

Drives: SX or DPS.





Tow-mode for water sports

Available for all single Aquamatic installations with the side-mounted control. When activated, the engine is limited to your preset maximum rpm, and maintains that speed, compensating for any changes in load. Easy to fine-tune with +/- buttons. This gives perfect speed all the time, every time, for for maximum water sport fun.

Joystick docking

Easy and logical one-hand maneuvering – simply move the joystick in the direction you want the boat to move, and the boat reacts to your intentions. Available for twin V8 with Duoprop drives.

EVC features

Electronic controls (shift & throttle)	●
Engine protection	●
Engine monitoring	●
Engine diagnostics	●
Engine synchronization	●
Transmission protection	●
Engine alarms in text	●
Plug-in instrument installation	●
NMEA 2000 interface	○
Trip computer	○
Instrumentation dimmer	●
Depth, seawater temp and speed	○
Tow-mode ⁴⁾	○
▶ Cruise control	○
▶ Single-lever mode ¹⁾	○
Joystick ^{2,3)}	○
Docking station ^{2,3)}	○
Autopilot interface ^{2,3,5)}	○
Electronic steering ²⁾	○
Powertrim sync ¹⁾	●
Powertrim assistant	○
Adjustable trim limits	●

● Standard ○ Optional ▶ New

¹⁾ Twin installation. ²⁾ Twin installation, V8, Duoprop drives. ³⁾ Requires electronic steering. ⁴⁾ Single installation. ⁵⁾ Volvo Penta certifies marine autopilot manufacturers for compatibility with Volvo Penta Aquamatic.

What is standard or optional varies by market.

Accessory packages
Read more on page 37.

8.1 – BIG-BLOCK V8

Big-block V8, the ultimate in gasoline power at 375, 400 and 420 hp. The 8.1 features electronic fuel injection with advanced monitoring system to ensure high reliability.

Drive: DPS.



Power range 190–420 hp

	Power (hp)			
4.3	190	225		
5.0/5.7		270	300	320
		270	300	320
8.1	375	400	420	

with catalytic converter

Complete technical data on page 39.

THE BENEFITS OF VOLVO PENTA IPS:

- 40% longer cruising range
- 20% higher top speed
- 30% reduced fuel consumption
- 30% less CO₂ emissions
- 50% lower perceived noise level
- Safe and predictable handling
- Joystick docking

Compared with inboard shafts at cruising with planing hulls, approximate figures.

A NEW ERA IN **YACHT POWER**

Volvo Penta IPS is the modern inboard system, superior to inboard shafts in every vital aspect – handling, onboard comfort and performance. It is a new era.



Volvo Penta IPS has been developed as the most environmentally sound inboard propulsion system. For Volvo Penta, green is more than a color. It's a commitment.



IPS1050 and IPS1200 are powered by the D13 engine. With the unique twin-entry, dual-stage turbo, you will be amazed by its performance.



Volvo Penta IPS is a proven success and by far the most popular pod system for leisure boats. Available for twin, triple and quadruple installation, the range suits boats and yachts from 30 to 100 feet. Always easy to drive with standard twin controls and the same great savings on fuel.

IPS350/400/450/500/550G/600

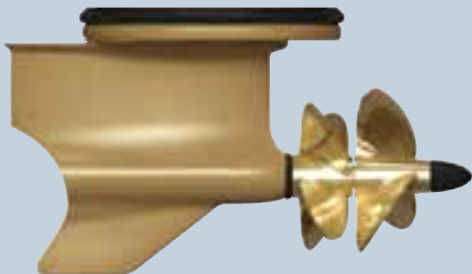

IPS800/900

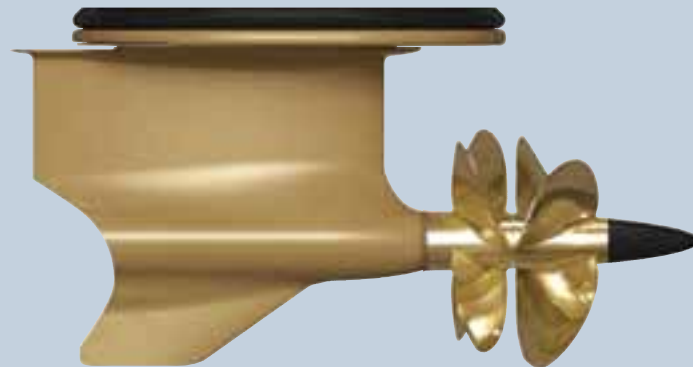

IPS1050/1200

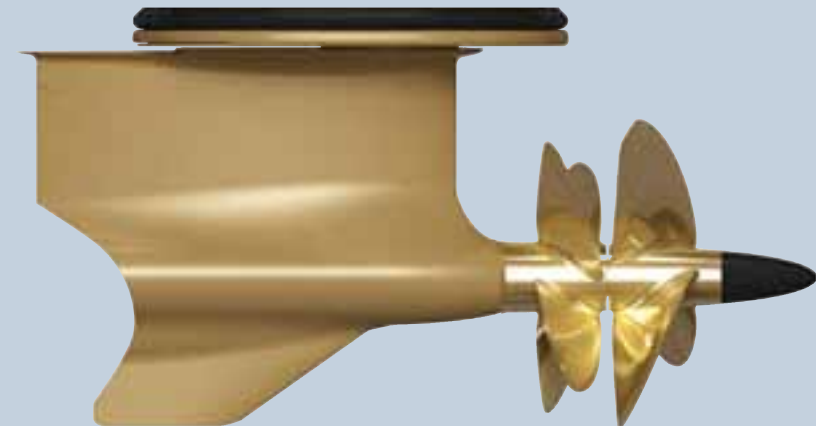

Three pod sizes – perfectly matched to each engine's power and torque.

WHY **FORWARD FACING** IS SO SUPERIOR

Volvo Penta IPS provides what seems to be an impossible combination: dramatically improved performance, longer cruising range and, at the same time, radically reduced CO₂ emissions – compared with inboard shafts.



Steerable pods

Steerable pods point the entire thrust in the desired direction. The boat is absolutely course-stable and the turning radius is tight, with perfect grip and predictable handling through the whole speed range.

FORWARD-FACING EFFICIENCY

The twin counter-rotating propellers face forward and work in undisturbed water. The propeller thrust is parallel with the hull. All power drives the boat forward.

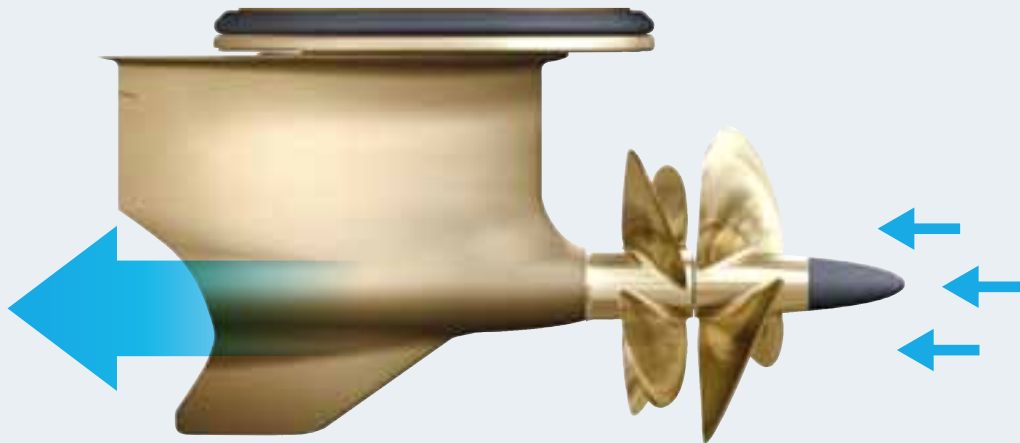

VIRTUALLY NO FUMES

All exhaust fumes are emitted through the pods, into the prop wash and carried well behind the boat for improved onboard comfort.

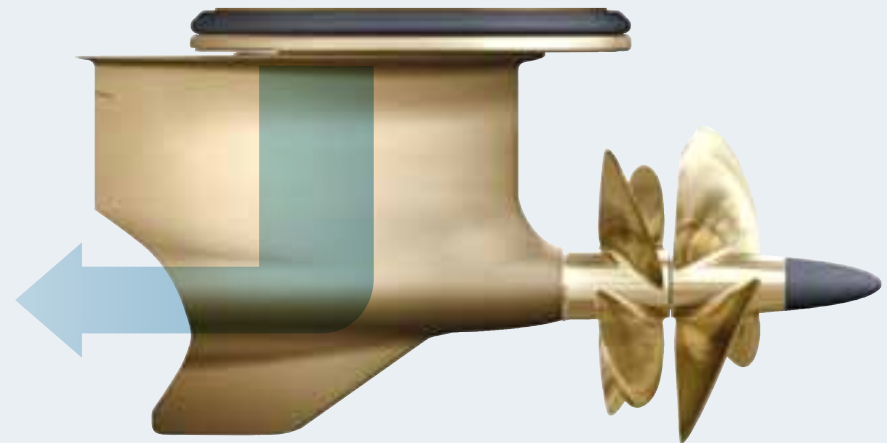



Efficiency

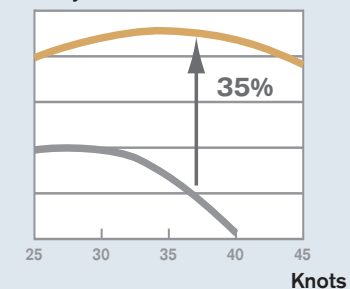

The forward-facing solution and an efficient flat-surface planing hull. The result is around 35% better efficiency at fast cruising than inboard shafts.

CAVITATION-FREE

The propellers are positioned well under the hull to eliminate the risk of air intrusion and cavitation, even in sharp turns and under full acceleration.

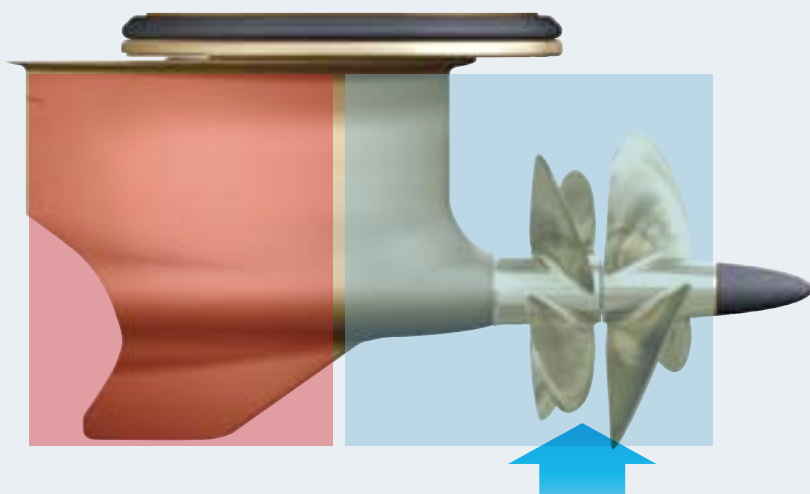

BLADE AREA EQUALS EFFICIENCY

Forward-facing propellers, with no exhausts through the hub, minimize the hub diameter. This gives a proportionally much larger active blade area, and better grip in the water.

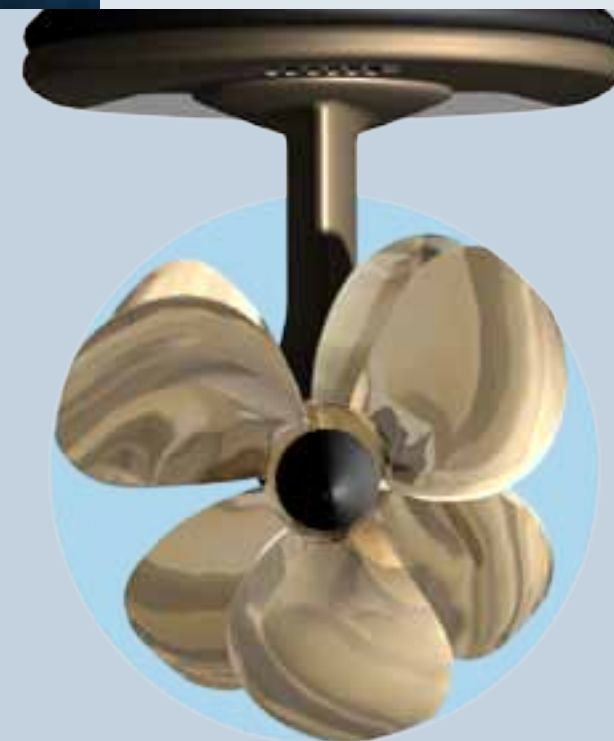

EASIER BOATING

RELAXED AND FUN DOCKING!

Volvo Penta IPS is available with a range of features that can be tailored to your personal preferences. With the joystick and Dynamic Positioning System, docking and maneuvering in close quarters is so easy it becomes pure fun.



DYNAMIC POSITIONING SYSTEM

Press a button and the Dynamic Positioning System holds your boat's position and heading and keeps it within a very limited area. The perfect feature for waiting at the fuel dock or for a bridge or lock to open. When docking, the Dynamic Positioning System gives your crew time to prepare fenders and lines.

High-precision GPS receivers determine the boat's position and heading. Software in the EVC system transforms this data into steering angles, gear shifts and throttle positions to keep the boat still.





DOCKING STATION

You can make docking even easier with additional joysticks. Place them wherever you have the best possible view for maneuvering. Up to four joysticks can be installed.



JOYSTICK

The skipper's best friend that makes docking easy, even fun. Forget complicated shift, throttle and steering wheel combinations in close-quarter maneuvering – simply move the joystick in the direction you want the boat to move: sideways, diagonally, forwards, backwards or rotate.

SMART FUNCTIONS FOR COMFORTABLE DRIVING

Volvo Penta IPS enables a number of smart functions for easier, more comfortable driving and better fishing. All equally simple to use thanks to the new control. Enjoy a new level of easy driving, no matter if it is a twin, triple or quadruple installation!



Low-speed mode

Integrated in the controls and perfect when driving in marinas and canals. The adjustable low-speed mode works by a slip coupling in the gearbox, which reduces boat speed at idling by around 50%, from 5–6 knots to 2–3 knots.



Single-lever mode

Lets you control twin, triple or quad engines with one lever. Very comfortable and safe when driving in rough seas.



Cruise control

The driver can fine-tune speed with the easy-to-reach button on the control.

Tailor your control! All the details on page 31.



UNIQUE SPORTFISH FEATURES

Volvo Penta IPS offers features that greatly improve fishability. All easily managed from the sportfish panel.

Sportfish mode makes the boat extremely maneuverable. The pods are locked toe-out, making it possible to rapidly turn the boat around its own axis and follow the fish at high speed in reverse, using only the engine controls.

Clear wake exhaust system bypasses the exhausts to the side of the boat. This cleans up the water behind the boat from exhaust bubbles, making it easier for the fish to see the bait (available for IPS800-IPS1200).

Single-lever mode makes it possible to operate shift and throttle for all engines with one lever.

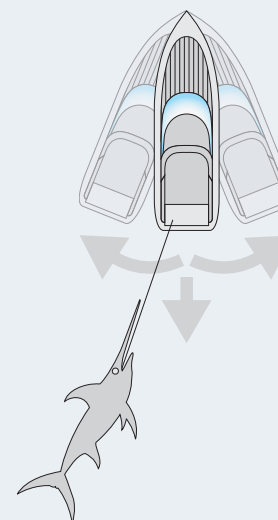

MULTIPLIED SIMPLICITY

Volvo Penta IPS is available for twin, triple and quadruple installation – making forward-facing efficiency available for yachts all the way up to 100 feet.

As easy as twin

Driving a boat with triple or quadruple installation is as easy as a twin. The same standard twin control and steering wheel are used. All the features, including the joystick, are available. Driving is a lot easier than with inboard shafts – and much more fun!

A revolution in yacht design

The compact aft installation opens completely new design opportunities with more space for accommodation. Often an entire extra cabin.

THE WIDEST POD RANGE

The Volvo Penta IPS range is by far the most complete on the market. No less than ten models, matched to three pod sizes and available as twin, triple and quadruple. New models this year are the IPS1050 and IPS1200, both powered by the D13 marine diesel.

Application chart

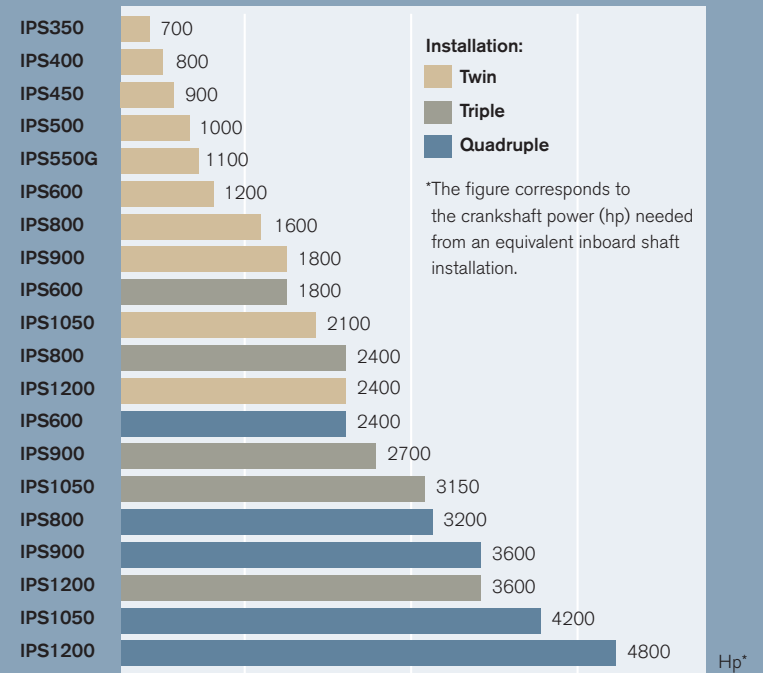

Volvo Penta IPS offers a complete range for yachts, sport cruisers and sportfishing boats up to 100 feet. All options are equally easy to drive with standard twin controls and all accessories available.

IPS550G

V8-powered gasoline with catalytic converter at 400 hp. Available in selected markets.



The Dynamic Positioning System is not available for IPS550G.

IPS350 AND IPS400

Powered by the D4, a 3.7-liter, 4-cylinder EVC-managed, common-rail diesel with turbo, compressor and aftercooler. 260 and 300 hp.

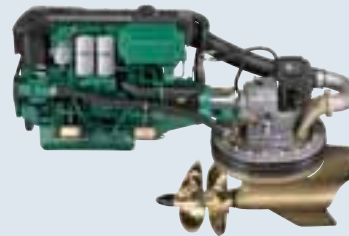

IPS450, IPS500 AND IPS600

Powered by the 6-cylinder D6, this 5.5-liter, EVC-managed common-rail diesel with turbo, compressor (500 and 600) and aftercooler delivers 330, 370 and 435 hp.

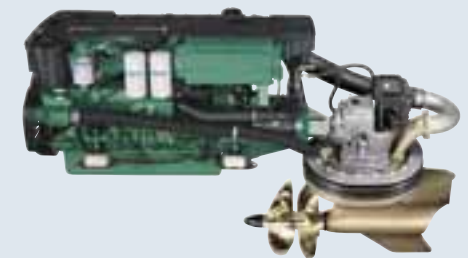

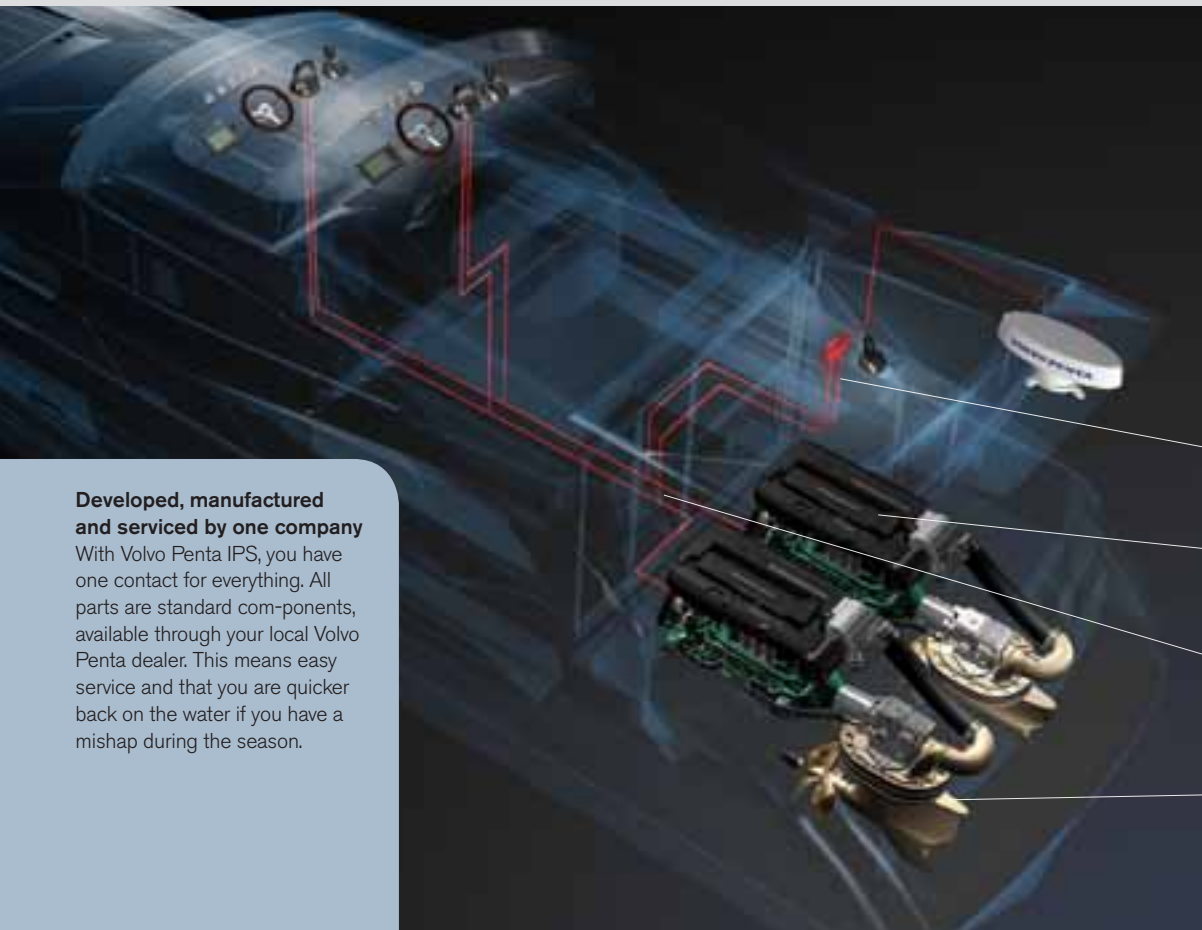

Developed, manufactured and serviced by one company

With Volvo Penta IPS, you have one contact for everything. All parts are standard components, available through your local Volvo Penta dealer. This means easy service and that you are quicker back on the water if you have a mishap during the season.

THE PERFECT MATCH

Volvo Penta IPS is a complete and integrated propulsion system – from the helm station to the propellers. This greatly increases quality and reliability.

Two separate systems and reliable take-me-home functionality give redundancy.

Powerful, low emission marine engines perfectly matched to the system.

Radically reduced wiring and heavy-duty marine connectors.

Forward-facing, high-efficiency pod system designed with safety as a key feature.

EVC features

Electronic controls (shift & throttle)	●
Engine protection	●
Engine monitoring	●
Engine diagnostics	●
Engine synchronization	●
Up to 4 helm stations	●
Transmission protection	●
Engine alarms in text	●
Plug-in instrument installation	●
NMEA 2000 interface	○
Trip computer	○
Instrumentation dimmer	●
Depth, seawater temp and speed	○
Joystick	○
Docking station	○
Autopilot interface ³⁾	○
Sportfish mode	○
▶ Clear wake exhaust ⁴⁾	○
Low-speed mode ¹⁾	●/○
Dynamic Positioning System ²⁾	○
▶ Single-lever	○
▶ Cruise control	○

● Standard ○ Optional ▶ New

¹⁾ Standard on IPS800-IPS1200, optional for other diesel models. ²⁾ Requires low-speed mode and 7" display. Only diesel models. ³⁾ Volvo Penta certifies marine autopilot manufacturers for compatibility with the Volvo Penta IPS. ⁴⁾ IPS 800-IPS1200

What is standard or optional varies by market.



Accessory packages
Read more on page 37.

IPS800 AND IPS900

Powered by the 6-cylinder D11. An 11-liter, EVC-managed diesel with twin entry turbo, mechanical compressor and after-cooler delivering 600 and 700 hp.

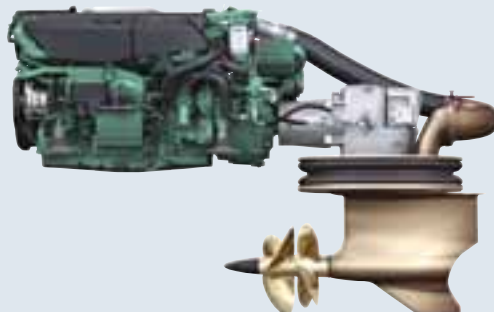

IPS1050 AND IPS1200

Powered by the 6-cylinder D13 EVC managed diesel. Awesome power and generous torque thanks to dual-stage turbocharger and delivering 800 and 900 hp.

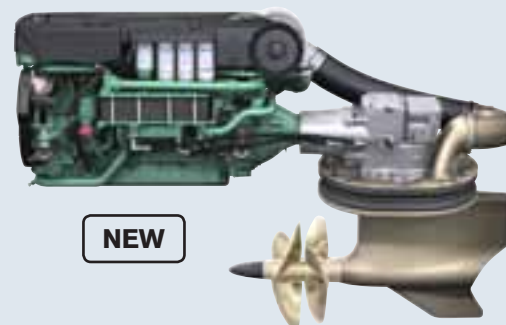

Power range IPS350-IPS1200

Diesels	Power (hp)	Engine
IPS350	260	D4
IPS400	300	D4
IPS450	330	D6
IPS500	370	D6
IPS600	435	D6
IPS800	600	D11
IPS900	700	D11
IPS1050	800	D13
IPS1200	900	D13
Gasoline	Power (hp)	Engine
IPS550G	400	V8

Complete technical data on page 38.

DIESEL INBOARD RANGE

The unique marine torque really excels in the Volvo Penta inboard range. You will experience massive maneuvering power, forceful acceleration on to the plane and enough power to keep a heavy boat at a good cruising speed. All this at low fuel consumption.



Robust control center

The new series of controls is your complete command center. Ergonomical and easy to use, designed for smooth driving. Everything is easy to reach, without letting go of the control! Page 31.



D1 AND D2 – THE COMPACT PERFORMERS

Low-rpm diesels for minimal vibrations and noise. 115 A alternator and built-in charging sensor for optimum battery charging. 2, 3 or 4 cylinders, 12 to 75 hp.



D3 – VERSATILE PERFORMER

In-line 5-cylinder diesels with very low exhaust and noise emissions. Five output options from 110 to 220 hp; two are low-rev versions for displacement boats. Electronic controls are standard on all models.



D13 – POWER AND EFFICIENCY

This is an engine with outstanding overall performance, yet quiet and smooth running. The fuel economy is world class with low emission of CO₂. The secret behind this is the centre mounted twin-entry turbo and on the 900 also a dual stage turbo. 800 (new) or 900 hp.

NEW



D13-800

Tailor your control!



Low-speed mode

Provides easy maneuvering and docking by reducing boat speed at idling by approximately 50%. Integrated in standard controls.

Single-lever mode

Drive twin engines with one lever. Easy and precise even in rough seas.

Cruise control

The driver can fine-tune speed with the easy-to-reach button on the control.

All the details on page 31.

EVC features

Electronic controls ¹⁾	●
Engine protection ¹⁾	●
Engine monitoring ¹⁾	●
Up to 4 helm stations.	●
Engine diagnostics ¹⁾	●
Engine synchronization ¹⁾	●
Transmission protection ¹⁾	●
Engine alarms in text ²⁾	●
Plug-in instrument installation	●
NMEA 2000 interface	○
Trip computer ¹⁾	○
Instrumentation dimmer	●
Depth, seawater temp and speed	○
Low-speed mode ^{3,5)}	●/○
▶ Cruise control ¹⁾	○
▶ Single-lever mode ^{1,4)}	○

● Standard ○ Option ▶ New

¹⁾ D3-D13. ²⁾ D1/D2 has alarm symbols. ³⁾ D4-D13.

⁴⁾ Twin installation. ⁵⁾ Standard on D13 with MXG gearbox.

What is standard or optional varies by market.



Accessory packages
Read more on page 37.

D4 AND D6 – COMMON RAIL POWER

Common rail, EVC and 4-valve technology deliver 180 to 435 hp. Smooth running with further reduced vibrations thanks to optimized engine suspension.



D9 AND D11 – MASSIVE TORQUE

Extremely powerful at all engine speeds, yet compact in size. The unique twin-entry turbo enables pulse charging, creating a magnificent torque for powerful acceleration. Easy to service, with all fuel and oil filters at the back of the engine. 500 to 670 hp.



Power range 12-900 hp

	Power (hp)				
D1	12	19	28		
D2	40	55	75		
D3	110	150	170	200	220
D4	180	225	260	300	
D6	330	370	435		
D9	500	575			
D11	670				
D13	800	900			

Complete technical data on page 38.

CONTROL THE POWER

Welcome to a better driving experience! Our new generation controls are designed around the driver for a new level of control.



Side-mounted for Aquamatic single installation.

Conveniently located push-buttons for functions and features:

- Cruise control and tow-mode adjustment.
- Tow-mode on/off.
- Cruise control on/off.
- Powertrim assistant on/off.

Standard and option, see table.



Conveniently located push-buttons for functions and features:

- Powertrim assistant on/off.
- Cruise control on/off.
- Low-speed mode on/off.
- Single-lever mode on/off.
- Station on/off/lock.
- Throttle only.

Standard and option, see table.

Top-mounted for single or twin installations.

Top-mounted, reverse view.



Individual Powertrim (SB)

Individual Powertrim (PT)

Cruise control rpm adjustment

Neutral indicator lights up when gear is in neutral.

Electronic shift and throttle

TAILOR YOUR CONTROL!

	IPS	Inboard		Aquamatic		
Engine installation	Twin ¹⁾	Twin	Single	Twin	Single	Single
Features						
Throttle only	●	●	●	●	●	●
Station on/off/lock	●	●	●	●	●	
Engine RPM sync	●	●		●		
Trim button in lever				●	●	●
Individual SB/PT trim buttons				●		
Safety lanyard						●
Cruise control	○	○	○	○	○	○
Single-lever mode	○	○		○		
Low-speed mode	○/● ²⁾	○ ³⁾	○ ³⁾			
Powertrim Assistant				○	○	○
Tow-mode						○

● Standard ○ Optional ¹⁾ Also for triple and quadruple installations ²⁾ Standard on IPS800-IPS1200 ³⁾ D4-D13

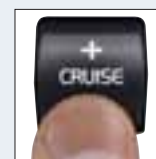

Cruise control

The driver can fine-tune speed with the easy-to-reach button on the control.



Powertrim assistant

Automatically gives you the best possible drive trim. The result is a perfect running attitude for optimum performance and low fuel consumption.



Single-lever mode

Operate twin engines with one lever. Easy and precise even in rough seas.



Tow-mode

For all single Aquamatic installations with the side-mounted control. When activated, the engine is limited to your preset maximum rpm, and maintains that speed, compensating for any changes in load. Easy to fine tune with +/- buttons. This gives perfect speed all the time, every time, for maximum water sport fun.



Low-speed mode

Reduces boat speed at idling by 50 % from 5-6 knots to 2-3 knots. Integrated in control and perfect when driving in marinas and canals.

ALL-INCLUSIVE INFORMATION

Multi-information displays make it possible to have all the information you want in one place. This year we are introducing a new interface for the 7" display and a new compact 2.5" display.

The EVC system makes multi-information displays possible. In these displays you can get engine data, trip computer information, diagnostic messages and manage the various EVC functions.

7" full color display

Top-of-the-line with full color and further improved interface. Operation is intuitive thanks to the easy-to-understand menus. Up to three engines can be displayed.

2.5" display

2.5" display that is easy to navigate and customize with backlit push-buttons. High readability in all light conditions.

4" display

Can show data from two engines at the same time. Five push-buttons make it easy to navigate. (No EVC settings.)

Trip computer software

As an option in combination with the multi-information displays, you can get full trip computer functionality. For available data, see the table.

Engine data in plotter

The NMEA 2000 interface, combined with a compatible chart plotter, is complementary to a multi-information display. It makes it possible to display engine data and alarms in the plotter.



The 7" full-color display shows all available information for up to three engines in a new interface. Digital or analogue readers, your tailored view or standard view, etc. Active software functions, such as low-speed mode, are displayed. There is also a video input for an onboard camera. Operation is intuitive thanks to the easy-to-understand menus.



The fuel economy view gives you detailed information on your boat's current and average fuel economy.



Easy-to-navigate menu leads you quickly to the information you want.



The 2.5" display is an information center in a compact size.

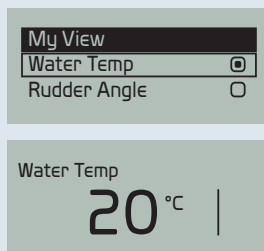

The "My View" function makes it easy to select the information you want.



With a camera connected, you can monitor the engine room or get better stern visibility for increased safety.



Engine view gives you all the engine data you need. Logically displayed with up to three engines on one screen.



The 4" display is an information center for one or two engines. Push-buttons for easy navigation.

Multi-information displays

Features and data	2.5"	4"	7"	Tacho-meter
Color screen			●	
Day/night mode			●	
Pop-up menus (shortcuts)			●	
Video input			●	
Neutral beep (on/off)	●	●	●	
Engines displayed (max)	1	2	3	1
Engine rpm	●	●	●	●
Engine hours	●	●	●	●
Coolant temperature	●	●	●	
Voltage	●	●	●	
Oil pressure *	●	●	●	
Turbo pressure (diesel) *	●	●	●	
Alarms and warnings	●	●	●	●
Diagnostics in text	●	●	●	
Diagnostics in text, extended info			●	
Transmission, oil pressure **	●	●	●	
Transmission, oil temperature **	●	●	●	
Boat speed ¹⁾	●	●	●	
Fuel level ²⁾	●	●	●	
Fresh water level ²⁾	●	●	●	
Depth with alarm ²⁾	●	●	●	
Sea water temperature ²⁾	●	●	●	
Rudder angle ²⁾	●	●	●	
Powertrim angle (Aquatic)	●	●	●	
Active Corrosion Protection info ³⁾	●	●	●	
Low-speed mode, slip rate ⁴⁾	●	●	●	
With Trip computer software	○	○	○	
Instant fuel rate	●	●	●	
Trip time	●	●	●	
Trip fuel	●	●	●	
Average fuel rate	●	●	●	
Time to empty	●	●	●	
Instant fuel economy ¹⁾	●	●	●	
Trip distance ¹⁾	●	●	●	
Average fuel economy ¹⁾	●	●	●	
Distance to empty ¹⁾	●	●	●	
With Dynamic Positioning System	○	○	○	
Bearing			●	
Direction of movement			●	
GPS signal strength			●	

* Not available for D1 and D2. ** Depending on transmission. Requires sensors. ● = Standard ○ = Optional.

¹⁾ Requires extra sensor or NMEA interface. ²⁾ Requires extra sensor. ³⁾ Volvo Penta IPS. Requires Active Corrosion Protection. ⁴⁾ Requires low-speed mode.



Complete instrument range

Built to the highest marine standards with anti-fogging membrane and full backlighting. Complement to 2.5" or 7" display.

Main instruments (85 mm/110 mm)

- Tachometer with engine hours and alarm symbols in LCD-display.
- Speedometer (requires sensor).

4-in-1 instrument (110 mm)

Fuel level, coolant temperature, voltage and oil pressure for inboard, or trim position for Aquamatic.

Additional instruments (52 mm)

Coolant temperature; trim position, analogue reading; trim position, digital reading; fuel tank level; rudder position; water tank level; turbo pressure; battery voltage; engine oil pressure.

Easy installation

Thanks to the EVC system, installing additional instruments is simple plug-in.



Backgrounds are available in white or black, trim in black or chrome.

Control panels

With different setups, they are available as complementary controls for various EVC functions, such as cruise control and Powertrim. They are default for sportfish mode and joystick docking station.



Cruise control



Powertrim



Sportfish



PROPELLERS

Matched propellers

Volvo Penta is world-leading in propeller design. Each propeller is developed together with the specific drive and engine series. The design is unique and gives high efficiency at all speeds, safe handling and excellent onboard comfort.



Single propellers

The single propellers are made from aluminum or high-performance stainless steel and are available for right- and left-hand rotation.

Duoprop propellers

Twin, counter-rotating propellers – with patented blade design – give perfect handling, easy maneuvering, excellent grip and long drive-train life. Advanced materials are used to optimize the range for different needs.

Volvo Penta IPS propellers

Unique pulling propellers with a patented design. These twin, counter-rotating propellers are made from a specially developed nickel-bronze-aluminum alloy.

Propellers	Aquamatic					Volvo Penta IPS		
	SX	DPS	DPH	DPR	OCEAN X	350-600	800-900	1050-1200
Type SX (single), 3-blade aluminum	●							
Type SX (single), 4-blade aluminum	●							
Type SX (single), 3-blade stainless steel	●							
▶ Type I, aluminum		●			●			
Type F, stainless steel		●			●			
Type G, nickel-bronze-aluminum			●					
Type GR, stainless steel				●				
Type T, nickel-bronze-aluminum						●		
Type P, nickel-bronze-aluminum							●	
▶ Type Q, nickel-bronze-aluminum								●

▶ New



Boat Trim System

The Boat Trim System with its patented interceptor technology gives you perfect control over pitch and heel with rapid response, quicker to the plane, lower fuel consumption and a more comfortable ride. Maintenance is practically zero thanks to composite material and no hydraulics.



You get:

- Improved fuel efficiency
- Greater lift and less drag compared to conventional trim tabs
- Quickly onto the plane
- Intuitive, user-friendly control panel
- Auto-retract at engine shut-off to minimize marine growth

Automatic Boat Trim System

The optional Boat Trim System can give you a perfect ride – automatically!

Trim the boat manually to your preferred attitude and press the “A” button. Now the boat attitude is stored in the system memory – even when the power is shut off.

The automatic boat trim takes over the trim job and keeps the boat's attitude. It automatically compensates for changes in speed, wind or people moving about on board. Thanks to the integrated GPS receiver it also senses changes in course, and does not compensate for heeling in turns.



ENGINE ACCESSORIES

Maintain powerful charging

For boaters needing increased charging capacity, there are solutions optimized for each engine.

Extra alternator

For 12 or 24 V system, matched for each engine.

Charging distributor

For efficient charging of multiple battery banks.

Power take-off

For powering auxiliary equipment.



Secure engine reliability

Unclean diesel, water or microorganisms in the fuel can cause your engine to stop or fail to start. A pre-filter and a decontaminator are efficient ways to secure safe functionality – and reliability.

Fuel pre-filters

Efficient pre-filters protect the engine from water and particles. They are easy to inspect and clean for high reliability.

Diesel fuel decontaminator

Prevents microorganisms from clogging up the fuel system.

Lubrication, oil and coolant

Developed to meet the specific demands of Volvo Penta marine engines and transmissions. These products work perfectly in all operating temperatures and maintain their qualities even during long periods without use.



A wide accessory range

Volvo Penta offers a wide range of engine accessories. Here are just a few additional examples.

Exhaust system

Complete system with silencers, hoses, elbows etc.

Cooling system

Complete system, outlet valves for air heater or water heater also available.

Neutra-Salt

Neutra-Salt engine flushing system gives effective protection against internal corrosion on raw-water-cooled gasoline engines.

Active Corrosion Protection

The Active Corrosion Protection monitors the galvanic current flow in the water. When necessary, the system alerts and takes efficient counter measures to protect the metal parts exposed as well as extend the service life of the anodes.

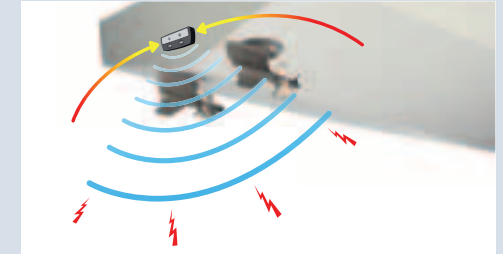

The Active Corrosion Protection is a benefit in marinas where stray currents are present, which can cause galvanic corrosion. Available for Volvo Penta IPS and sterndrives.

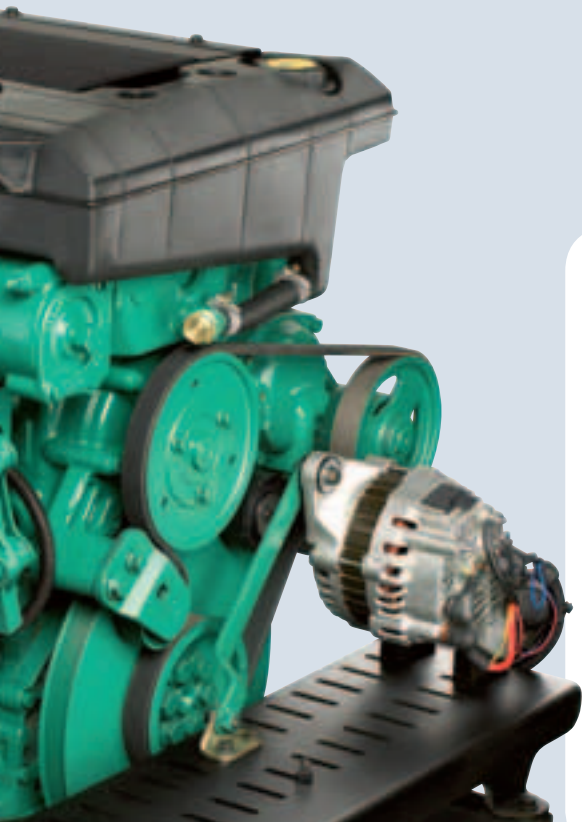

SAFETY AND ONBOARD COMFORT

Manual bilge pump

For safety reasons, you should always install a manual bilge pump.

Submersible electrical bilge pump

Reliable and ignition-proof water-cooled motor.

Float switches

Boost safety, activating the pump as soon as bilge water is detected.

Belt guard

Safe protection from moving parts on the engine.

Onboard kit

Pre-packed kits with the most common maintenance parts. Designed for each engine series and, of course, containing Genuine Volvo Penta Parts.

Safety lanyard

Stops engine if driver falls overboard.

Sound absorbent

Highly efficient sound-absorbent panels made for marine environment.







Air heater

Heats the cabin and/or defrosts the windshield by using the engine's excess heat.



EVC ACCESSORY PACKAGES

Complete packages for even better Drivability, Comfort, Economy and Monitoring. Everything needed – hardware and software is included in the EVC packages.

	 DRIVABILITY PACKAGES	 COMFORT PACKAGES	 ECONOMY PACKAGES	 MONITORING PACKAGES
VOLVO PENTA IPS	Drivability main kit ¹⁾ <ul style="list-style-type: none"> Joystick, software 7" color display Low-speed mode software ⁴⁾ Mounting kit Docking station kit <ul style="list-style-type: none"> Joystick, software EVC panel Dynamic Positioning System kit ³⁾ <ul style="list-style-type: none"> GPS receiver, software Sportfish mode <ul style="list-style-type: none"> Sportfish panel, software 	Comfort main kit <ul style="list-style-type: none"> Single-lever mode Cruise control 	Economy main kit <ul style="list-style-type: none"> Trip computer software NMEA 2000 interface Active Corrosion Protection kit <ul style="list-style-type: none"> Active Corrosion Protection main unit Software 	Included in Drivability main kit.
AQUAMATIC TWIN ENGINE	Drivability main kit <ul style="list-style-type: none"> Powertrim Assistant Rudder indicator, sender, interface kit Joystick kit <ul style="list-style-type: none"> Joystick, software Electronic steering Docking station kit <ul style="list-style-type: none"> Joystick, software EVC panel 	Comfort main kit <ul style="list-style-type: none"> Single-lever mode Cruise control 	Economy main kit <ul style="list-style-type: none"> Trip computer software NMEA 2000 interface 	Display kit ¹⁾ <ul style="list-style-type: none"> 7" color display Mounting kit
INBOARD TWIN ENGINE	Drivability main kit <ul style="list-style-type: none"> Low-speed mode software Rudder indicator, sender 	Comfort main kit <ul style="list-style-type: none"> Single-lever mode Cruise control 	Economy main kit <ul style="list-style-type: none"> Trip computer software NMEA 2000 interface 	Display kit ¹⁾ <ul style="list-style-type: none"> 7" color display Mounting kit
	 SINGLE ENGINE PACKAGES			 MONITORING PACKAGES
AQUAMATIC SINGLE ENGINE	Aquamatic single main kit ²⁾ <ul style="list-style-type: none"> Powertrim Assistant Trip computer software Multisensor 			Display kit ¹⁾ <ul style="list-style-type: none"> 4" Display NMEA 2000 interface
INBOARD SINGLE ENGINE	Inboard single main kit ²⁾ <ul style="list-style-type: none"> Low-speed mode Trip computer software Multisensor 			Display kit ¹⁾ <ul style="list-style-type: none"> 4" Display NMEA 2000 interface

Drive-specific options are presented in their respective sections:

Aquamatic (pages 10-17)
 Volvo Penta IPS (pages 18-27)
 Inboard shaft (pages 28-29)

¹⁾ Top- or flush-mounted ²⁾ Hull- or transom-mounted ³⁾ Requires Drivability main kit ⁴⁾ Standard on IPS800-1200

DIESEL INBOARD

Engine	Crankshaft kW/hp	Propeller shaft kW/hp	Rated rpm	Displacement liters	No. of cylinders	High-pressure fuel injection	Aspiration	Electronic management	Constant power	Electronic shift/throttle	Freshwater cooling	Alternator 12V	Alternator 24V	Saildrive
D1-13	9.0/12.2	8.6/11.8	3200	0.5	2	-	N	MDI	-	-	●	115A ¹⁾	-	130S
D1-20	14/19	13/18	3200	0.8	3	-	N	MDI	-	-	●	115A ¹⁾	-	130S
D1-30	21/28	20/27	3200	1.1	3	-	N	MDI	-	-	●	115A ¹⁾	-	130S
D2-40	29/40	28/38	3200	1.5	4	-	N	MDI	-	-	●	115A ¹⁾	-	130S
D2-55	41/55	39/53	3000	2.2	4	-	N	MDI	-	-	●	115A ¹⁾	-	130S
D2-75	55/75	53/72	3000	2.2	4	-	T	MDI	-	-	●	115A ¹⁾	-	150S
D3-110	81/110	78/107	3000	2.4	5	CR	T/A/4V	EVC	T/Q	●	●	150A	-	
D3-150	110/150	107/146	3000	2.4	5	CR	T/A/4V	EVC	T/Q	●	●	150A	-	
D3-170	125/170	121/165	4000	2.4	5	CR	T/A/4V	EVC	T/Q	●	●	150A	-	
D3-200	147/200	143/194	4000	2.4	5	CR	T/A/4V	EVC	T/Q	●	●	150A	-	
D3-220	162/220	157/213	4000	2.4	5	CR	T/A/4V	EVC	T/Q	●	●	150A	-	
D4-180	132/180	128/174	2800	3.7	4	CR	T/A/4V	EVC	T/Q	●	●	115A ¹⁾	-	
D4-225	165/225	160/218	3500	3.7	4	CR	T/A/4V	EVC	T/Q	●	●	115A ¹⁾	-	
D4-260	191/260	186/253	3500	3.7	4	CR	T/A/4V	EVC	T/Q	●	●	115A ¹⁾	-	
D4-300	221/300	212/288	3500	3.7	4	CR	T/A/4V	EVC	T/Q	●	●	115A ¹⁾	-	
D6-330	243/330	237/322	3500	5.5	6	CR	T/A/4V	EVC	T/Q	●	●	115A ¹⁾	80A ¹⁾	
D6-370	272/370	267/363	3500	5.5	6	CR	T/A/4V	EVC	T/Q	●	●	115A ¹⁾	80A ¹⁾	
D6-435	320/435	310/422	3500	5.5	6	CR	T/A/K/4V	EVC	T/Q	●	●	115A ¹⁾	80A ¹⁾	
D9-500	368/500	357/486	2600	9.4	6	UI	T/A/4V	EVC	T	●	●	115A ¹⁾	80A ¹⁾	
D9-575	423/575	410/558	2500	9.4	6	UI	T/A/4V	EVC	T	●	●	115A ¹⁾	80A ¹⁾	
D11-670	493/670	478/650	2300	10.8	6	UI	T/A/4V	EVC	T	●	●	-	80A ¹⁾	
▶ D13-800	588/800	564/768	2300	12.8	6	UI	T/A/4V	EVC	T	●	●	-	110A ¹⁾	
▶ D13-900	662/900	636/864	2300	12.8	6	UI	T2/A/4V	EVC	T	●	●	-	110A ¹⁾	

▶ New ● Standard ○ Optional □ Accessory

High-pressure fuel injection

UI: Unit injectors

CR: Common rail fuel injection

Fuel delivery

2-BBL: Two-barrel carburetor

MPI: Multi-port electronic fuel injection

Electronic management

EVC: Electronic Vessel Control, a CAN-bus-based boat management for drive line control including electronic shift and throttle, engine management, diagnostic function, instrumentation, accessories etc.

MDI: Interface for EVC instrumentation.

Aspiration

N: Naturally aspirated

A: Aftercooler

T: Turbocharger

K: Compressor

T2: Dual-stage turbochargers 4V: 4 valves per cylinder

Constant power

T: Temperature compensation. Constant power output regardless of fuel temperature (5–55°C).

Q: Quality compensation. Constant power output regardless of fuel viscosity (heavy, regular or environmentally adapted fuel).

Fuel consumption

Estimated fuel consumption can be found in the product bulletin for each engine, available on volvopenta.com. For estimated fuel consumption for a specific boat model, consult your boat dealer.

Transmissions

A wide selection of Volvo Penta marine gearboxes is available for all diesel inboard engines, including straight or down-angle output shafts, mechanically or hydraulically operated. Saildrive is available for engines from 12 to 75 hp.

Volvo Penta IPS comes as a complete propulsion system with gearbox and propulsion unit.

VOLVO PENTA IPS

Diesel

IPS350	191/260	182/248	3500	3.7	4	CR	T/A/K/4V	EVC	T/Q	●	●	115A ¹⁾	-	
IPS400	221/300	212/289	3500	3.7	4	CR	T/A/K/4V	EVC	T/Q	●	●	115A ¹⁾	-	
IPS450	243/330	230/314	3500	5.5	6	CR	T/A/K/4V	EVC	T/Q	●	●	115A ¹⁾	80A ¹⁾	
IPS500	272/370	259/352	3500	5.5	6	CR	T/A/K/4V	EVC	T/Q	●	●	115A ¹⁾	80A ¹⁾	
IPS600	320/435	307/418	3500	5.5	6	CR	T/A/K/4V	EVC	T/Q	●	●	115A ¹⁾	80A ¹⁾	
IPS800	441/600	417/567	2300	10.8	6	UI	T/A/K/4V	EVC	T	●	●	-	80A ¹⁾	
IPS900	515/700	487/662	2350	10.8	6	UI	T/A/K/4V	EVC	T	●	●	-	80A ¹⁾	
▶ IPS1050	588/800	564/768	2300	12.8	6	UI	T2/A/4V	EVC	T	●	●	-	110A ¹⁾	
▶ IPS1200	662/900	636/864	2300	12.8	6	UI	T2/A/4V	EVC	T	●	●	-	110A ¹⁾	

Gasoline with catalytic converter

IPS550G*	298/400	280/376	4800	8.1	V8	MPI	N	EVC	-	●	●	120A	-	
----------	---------	---------	------	-----	----	-----	---	-----	---	---	---	------	---	--

¹⁾ With built-in charging sensor * Only available in selected markets

DIESEL AQUAMATIC

Engine	Crankshaft kW/hp	Propeller shaft kW/hp	Rated rpm	Displacement liters	No. of cylinders	High-pressure fuel injection	Aspiration	Electronic management	Constant power	Electronic shift/throttle	Freshwater cooling	Alternator 12V	Aquamatic drive	X-act steering	Propellers*
D3-140	103/140	98/133	4000	2.4	5	CR	T/A/4V	EVC	T/Q	●	●	150A	SX/DPS	-	AL, SS
D3-170	125/170	119/162	4000	2.4	5	CR	T/A/4V	EVC	T/Q	●	●	150A	SX/DPS	-	AL, SS
D3-200	147/200	140/190	4000	2.4	5	CR	T/A/4V	EVC	T/Q	●	●	150A	DPS	-	AL, SS
D3-220	162/220	154/209	4000	2.4	5	CR	T/A/4V	EVC	T/Q	●	●	150A	DPS	-	AL, SS
D4-225	165/225	158/215	3500	3.7	4	CR	T/A/4V	EVC	T/Q	●	●	115A ¹⁾	DPH	●	NBR
D4-260	191/260	184/250	3500	3.7	4	CR	T/A/K/4V	EVC	T/Q	●	●	115A ¹⁾	DPH	●	NBR
D4-300	221/300	214/291	3500	3.7	4	CR	T/A/K/4V	EVC	T/Q	●	●	115A ¹⁾	DPH/DPR	●	NBR/SS
D6-330	243/330	233/317	3500	5.5	6	CR	T/A/4V	EVC	T/Q	●	●	115A ¹⁾	DPH	●	NBR
D6-370	272/370	261/355	3500	5.5	6	CR	T/A/K/4V	EVC	T/Q	●	●	115A ¹⁾	DPH/DPR	●	NBR/SS

¹⁾ With built-in charging sensor

* Not included

Aquamatic drives

SX: Single propeller. For gasoline engines and D3. Small transom cut-out.

DPS: Duoprop. For gasoline engines and D3. Small transom cut-out.

DPH: Duoprop. With X-act steering, specially developed for the D4 and D6 engines. Large transom cut-out.

DPR: Same as DPH, but with a lower housing adapted for speeds in excess of 45 knots. Large transom cut-out.

X-act steering

Servo-assisted hydraulic steering with external steering cylinders controlled by an exact feedback valve.

Propellers

AL: Aluminum

SS: Stainless steel

NBR: Nickel-bronze-aluminum alloy

Product bulletins with more detailed information available at your dealer or www.volvopenta.com

GASOLINE AQUAMATIC

Engine	Propeller shaft kW/hp	Max rpm	Displacement liters	No. of cylinders	Fuel delivery	Electronic management	Electronic shift/throttle	Freshwater cooling	Alternator 12V	Aquamatic drive	X-act steering	Propellers*
4.3GL	141/190	4600	4.3	V6	2-BBL	-	□	75A	SX/DPS	-	-	AL, SS
4.3GXIE	168/225	4800	4.3	V6	MPI	EVC**	●**	□	75A	SX/DPS	-	AL, SS
5.0GXIE	201/270	5000	5.0	V8	MPI	EVC**	●**	○	75A	SX/DPS	-	SS
5.7GIE-300	224/300	5000	5.7	V8	MPI	EVC**	●**	○	75A	SX/DPS	-	SS
5.7GXIE	239/320	5200	5.7	V8	MPI	EVC**	●**	○	75A	SX/DPS	-	SS
8.1GIE	280/375	4600	8.1	V8	MPI	EVC**	●**	○	75A	DPS	-	SS
8.1GXIE	313/420	5000	8.1	V8	MPI	EVC**	●**	○	75A	DPS	-	SS

Engines with catalytic converter

5.0GXICE	201/270	5000	5.0	V8	MPI	EVC**	●**	○	75A	SX/DPS	-	SS
5.7GXICE-300	224/300	5000	5.7	V8	MPI	EVC**	●**	○	75A	SX/DPS	-	SS
8.1GXICE	298/400	4800	8.1	V8	MPI	EVC**	●**	○	75A	DPS	-	SS

* Not included

** Standard or optional depending on market. Check with your local Volvo Penta representative.



Thanks to state-of-the-art engine technology throughout, the entire D-series diesel engine range complies with the most stringent environmental demands in their respective power classes:

- The US EPA Tier 2 for D3 to D13 and Tier 3 for D1 and D2, two regulations significantly more stringent than the European RCD regulation.

All our gasoline engines comply with:

- The European RCD regulation.

Models with catalytic converters also comply with:

- CARB 4 Star Super Ultra Low Emission, and US EPA.



GLOBAL DEALER NETWORK

With Volvo Penta, you have one single contact for everything: engines, instruments, accessories, service, warranties, etc. This means simpler ownership – and more time for boating. With every Volvo Penta engine comes the support of a global dealer network – present in more than 130 countries.

Volvo Penta Action Service



Volvo Penta Action Service is a unique service for all Volvo Penta owners. With this telephone service for rapid support, we offer 24/7 availability, 365 days a year. Volvo Penta Action Service is available in Europe and North America.

Extended protection

Warranties and extended protection for Volvo Penta engines give you years of protection, depending on local conditions. Contact your dealer for more information and for activating the extended protection.



VOLVO PENTA

www.volvopenta.com